

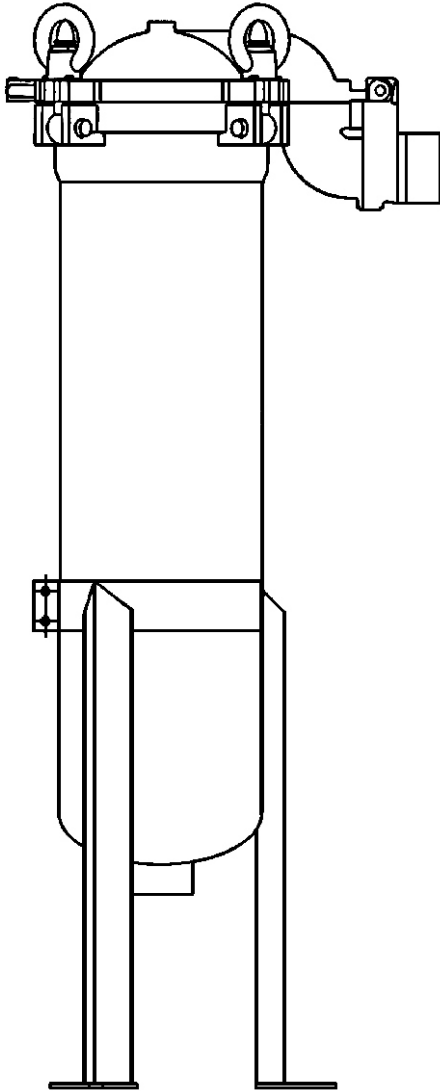

FHS OT (316SS) SERIES FILTER BAG HOUSING

The Arctic FHS OT (316SS) Series of Filter Bag Housings is our standard Over the Top (OT) line using 316SS. It utilizes the same high efficiency design as our FHP Premium Series but is designed for standard applications requiring a pressure rating of 150 PSI @ -29° C to 232° C.

The Over the Top design provides better contaminant loading, therefore increasing the time between bag changes. Locating the filter bag at the top of the housing makes it easier for the operator to change filter bags.



FEATURES

- OT design provides better contaminant loading & easier bag change-outs.
- Four swing bolt closures allow easy access without special tools.
- High quality castings provide easy and accurate filtration.
- 316SS Retainer Basket offers greater chemical resistance.
- Up to 180 US GPM with less than 2 PSI pressure drop. (Based on water-like viscosity and a clean filter bag.)
- SS Shot Blast facilitates easier vessel cleanup.
- Passivation of wetted parts provides increased corrosion resistance.
- Adjustable height 304SS three-leg stand.
- Cover rest to facilitate bag change-out.
- 100% hydraulic testing ensuring quality and performance.

OPTIONS

- Mesh Lined Retainer Basket (Eliminates need for filter bag.)
- 304 Stainless Steel Hardware
- ANSI Flanged Inlet and Outlet Kits
- Optional O-Ring materials in Buna N, EPR, Viton Encapsulated Teflon
- Electro Polishing
- Displacement Balloons
- Pressure Gauges and Switches
- Duplex or Multi-Plex Assemblies upon Request

FHS OT (316SS) SERIES FILTER BAG HOUSING

	P1	P2
DIM	2" FNPT	2" FNPT
A	23"	35"
B	15.0"	28.8"
C	6.3" - 6.5"	6.3" - 13.3"
D	11.0"	11.0"

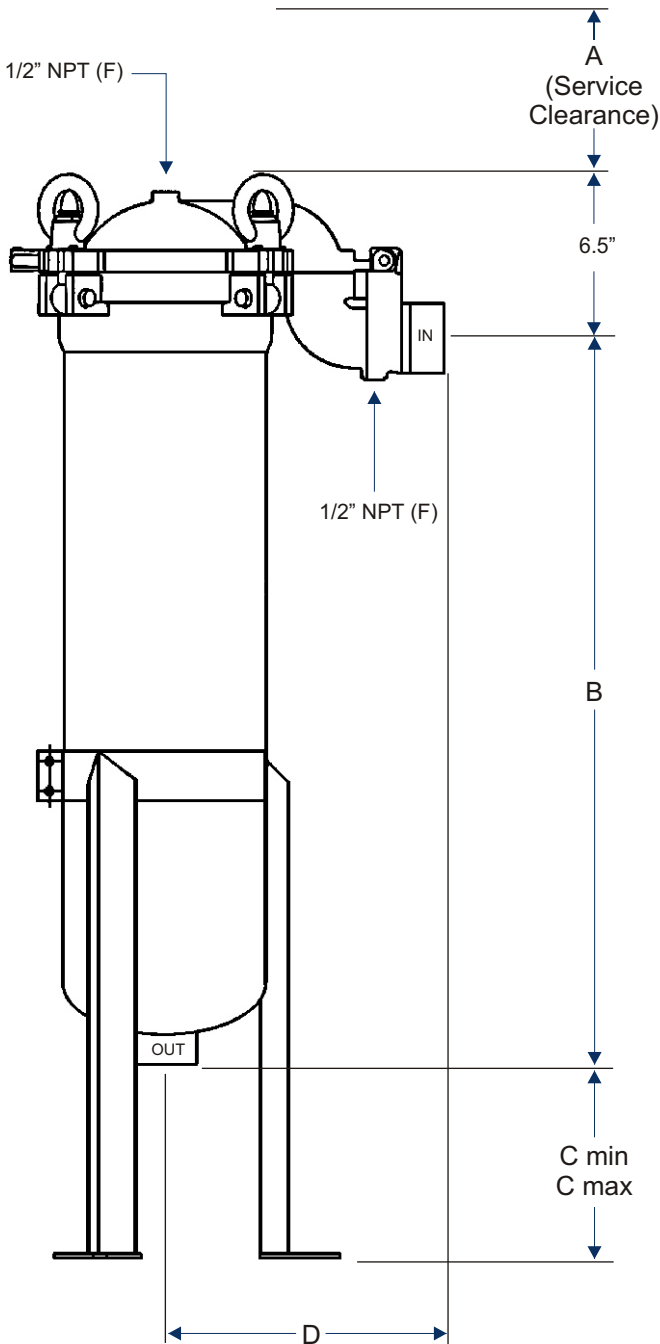

SPECIFICATIONS

Maximum Pressure: 150 psig
 Temperature: -29° C to 232° C (-20 °F to 450 °F)
 Liquid Volume: P1 4.5 US Gal
 P2 7.4 US Gal
 Maximum Flow Rate*: P1 90 USGPM
 P2 180 USGPM

* Based on new filter with water & a maximum pressure drop of 2 psig

Inlet and Outlet: 2" FNPT
 Gauge & Vent Port: 1/2" FNPT
 Goose Neck Drain Port: 1/2" FNPT
 Weight (Dry): P1 29 Kg
 P2 33 Kg

MATERIALS

Housing & Cover: 316 Stainless Steel
 Retainer Basket: 316 Stainless Steel, 1/8" perf.
 Hardware**: Galvanized Carbon Steel
 O-Rings (Standard): Viton
 3-Leg Stand: 304 Stainless Steel
 Name Plate**: Aluminum

** Stainless Steel is available as an option.

3-LEG STAND MOUNTING DETAIL

