

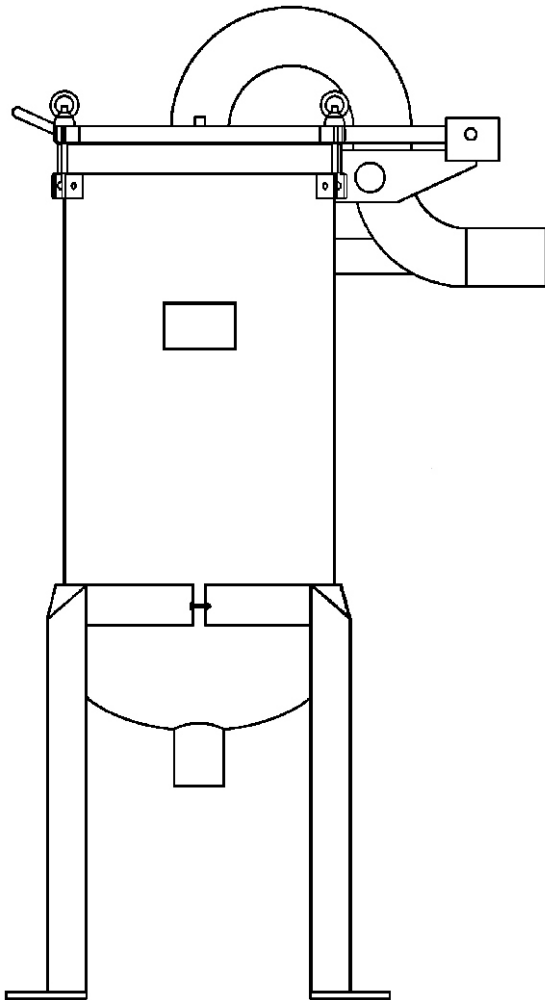

# FHS OT (CS) SERIES FILTER BAG HOUSING

The Arctic FHS OT (CS) Series of Filter Bag Housings is our standard Over the Top (OT) line using Carbon Steel (CS). It utilizes the same high efficiency design as our FHP Premium Series but is designed for standard applications requiring a pressure rating of 150 PSI @ -29° C to 160° C.

The Over the Top design provides better contaminant loading, therefore increasing the time between bag changes. Locating the filter bag at the top of the housing makes it easier for the operator to change filter bags.



## FEATURES

- OT design provides better contaminant loading & easier bag change-outs.
- Four swing bolt closures allow easy access without special tools.
- 304SS Retainer Basket offers greater chemical resistance.
- Up to 180 US GPM with less than 2 PSI pressure drop. (Based on water-like viscosity and a clean filter bag.)
- Glass Bead Blast facilitates easier vessel cleanup.
- Adjustable height three-leg stand.
- Built in cover rest facilitates bag change-out.
- 100% hydraulic testing ensuring quality and performance.

## OPTIONS

- Mesh Lined Retainer Basket (Eliminates need for filter bag.)
- 304 Stainless Steel hardware
- ANSI Flanged Inlet and Outlet Kits
- Optional O-Ring Materials in Viton, EPR, Viton Encapsulated Teflon
- Electro Polishing
- Pressure Gauges and Switches
- Duplex or Multi-Plex Assemblies upon Request

# FHS OT (CS) SERIES FILTER BAG HOUSING

	P1	P2
DIM	2" FNPT	2" FNPT
A	23"	35"
B	14.6"	29.5"
C	13.5" - 18.5"	6.3" - 18.5"
D	13.0"	13.0"

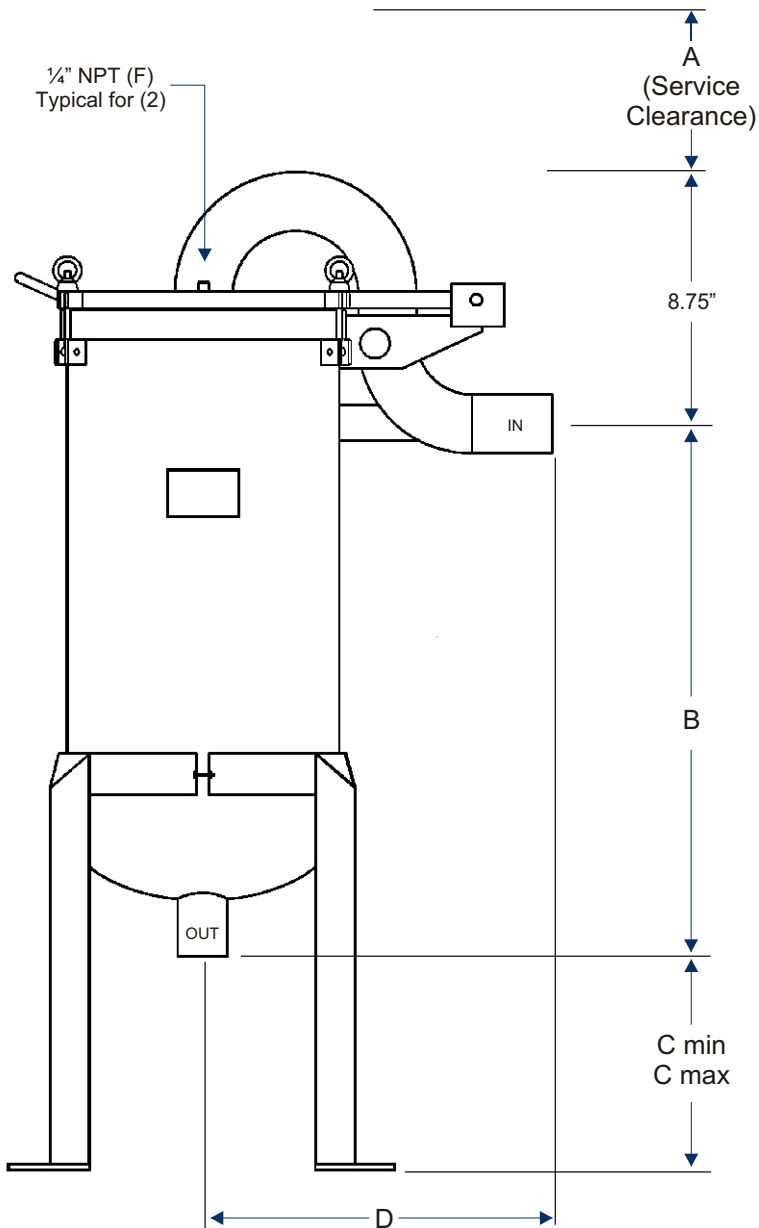

## SPECIFICATIONS

Maximum Pressure: ..... 150 psig  
 Temperature: . . -29° C to 160° C (-20° F to 320° F)  
 Liquid Volume: P1 ..... 3.4 US Gal  
                   P2 ..... 7.3 US Gal  
 Maximum Flow Rate\*: P1 ..... 90 USGPM  
                               P2 ..... 180 USGPM

\* Based on new filter with water & a maximum pressure drop of 2 psig

Inlet and Outlet: ..... 2" FNPT  
 Gauge & Vent Ports: ..... 2 x 1/4" FNPT  
 Weight (Dry): P1 ..... 29 Kg  
                   P2 ..... 36 Kg

## MATERIALS

Housing & Cover: ..... Carbon Steel Painted with High Temperature Enamel  
 Retainer Basket: . . . 304 Stainless Steel, 1/8" perf.  
 Hardware\*\*: ..... Galvanized Carbon Steel  
 O-Rings (Standard): ..... Buna-N  
 3-Leg Stand ..... Painted Carbon Steel  
 Name Plate\*\*: ..... Aluminum

\*\* Stainless Steel is available as an option.

## 3-LEG STAND MOUNTING DETAIL

