

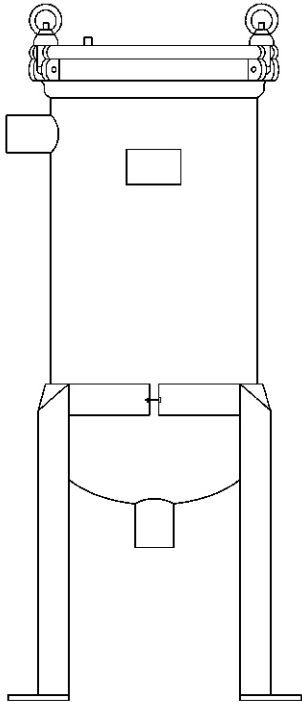

FHS SE (CS) SERIES FILTER BAG HOUSING

P1/P2



The Arctic FHS SE (CS) Series of Filter Bag Housings is our most popular line of Filter Bag Housing. The line is a Side Entry (SE) design and is our most economical choice in Carbon Steel (CS). It has a pressure rating of 150PSI @ -29° C to 160° C.

The Side Entry design has many of the quality features of our Over the Top design but its simpler layout allows for reduction in materials resulting in an economical choice. The Side Entry design in Carbon Steel is available in Sizes P1 through P4.

FEATURES

- Available in four sizes: P1, P2, P3 and P4.
- Four swing bolt closures allow easy access without special tools.
- High Quality Castings provide easy and accurate filtration.
- 304SS Retainer Basket offers greater chemical resistance.
- Up to 180 US GPM with less than 2 PSI pressure drop. (Based on water-like viscosity and a clean filter bag.)
- Glass Bead Blast facilitates easier vessel cleanup.
- Adjustable height three-leg stand.
- Cover rest to facilitate bag change-out.
- 100% hydraulic testing ensuring quality and performance.

P3/P4

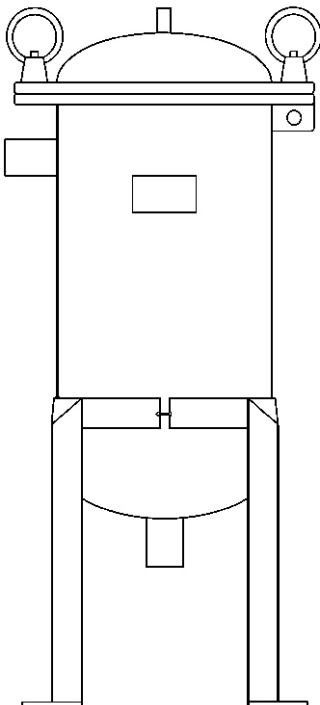

OPTIONS

- Mesh Lined Retainer Basket (Eliminates need for filter bag.)
- 304 Stainless Steel Hardware
- ANSI Flanged Inlet and Outlet Kits
- Optional O-Ring Materials in Viton, EPR, Viton Encapsulated Teflon
- Displacement Balloons
- Pressure Gauges and Switches
- Duplex or Multi-Plex Assemblies upon Request

